

# Model A Schematic

Drawn by Les Wittrup Revision 10/7/2022

## Starter

## Ammeter

## Ignition

## Generator

## Lights & Misc.

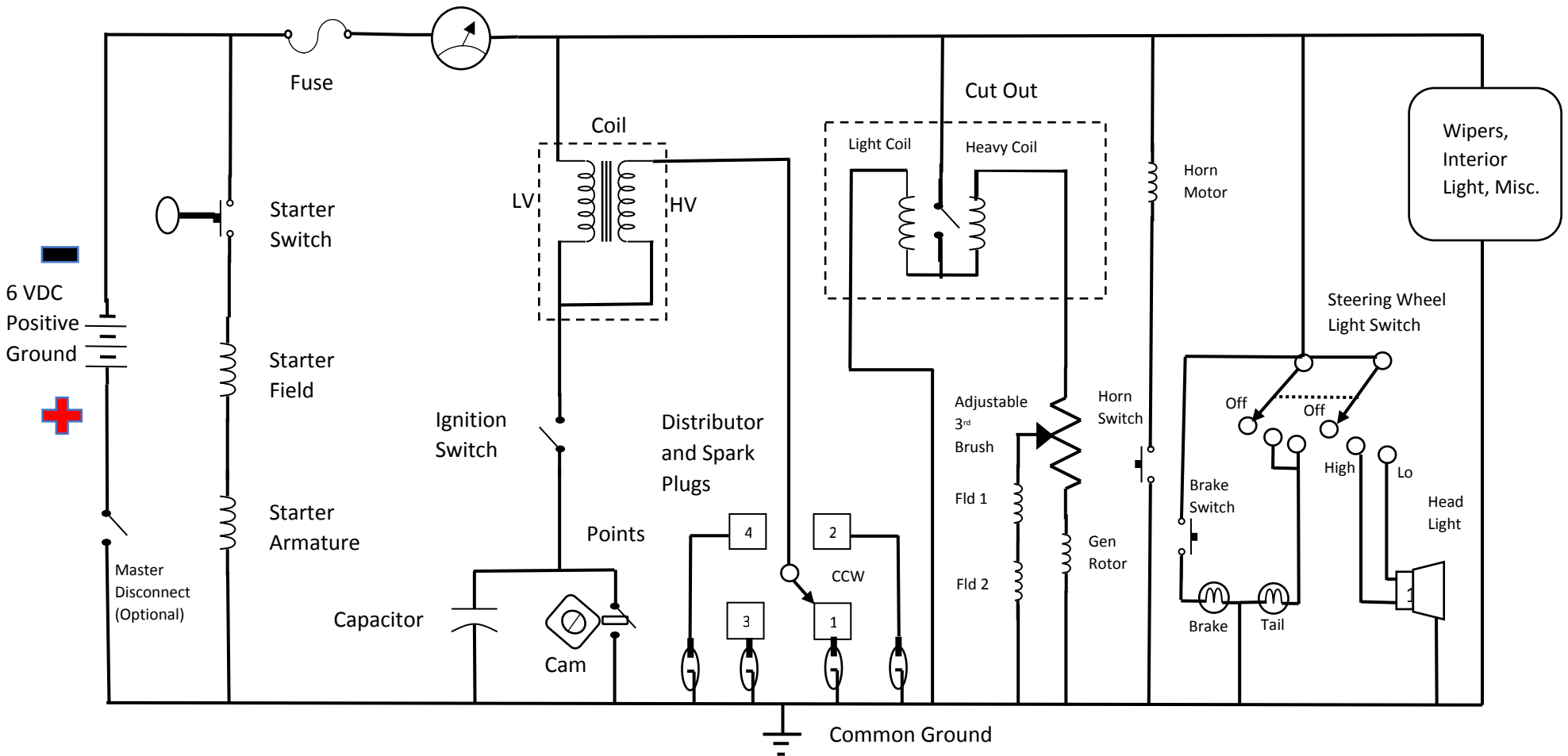

## How a Cut Out works! (Source: Vintage Ford Forum)

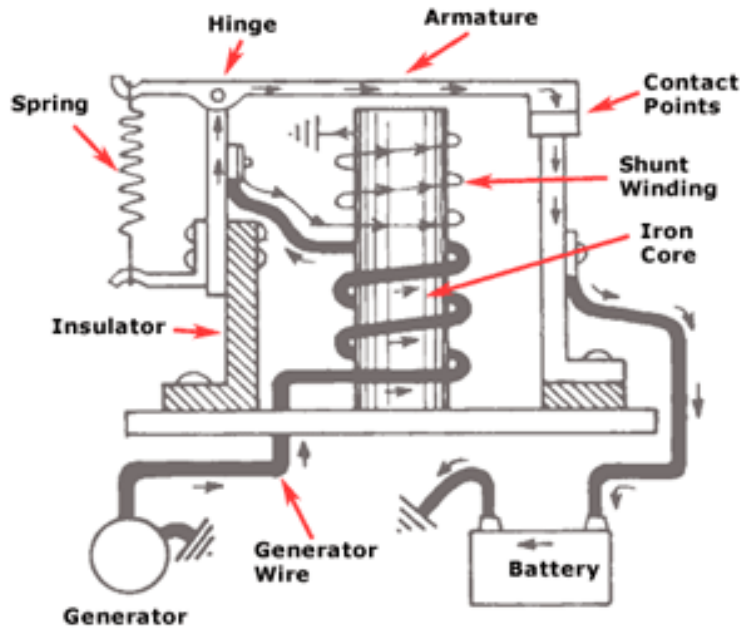

A Schematic of the cutout relay. Trace the flow of current through its components.

The cutout is simply an OFF-ON switch to disconnect the battery from the generator when the generator puts out less than battery voltage. Here is a good schematic of the cutout showing the two windings. The fine winding pulls the armature down to close the contacts, and the current flowing through the heavy winding helps hold it closed. When the generator voltage falls below battery voltage the battery current will reverse direction and run back into the generator. This will reverse the polarity of the heavy winding and cancel the pull of the fine winding, thus opening the contacts.

**Inner Coil**-The inner coil is made up of multiple windings of a thin wire around an iron core. The fine-wire winding is just enough to get the points to close when the generator voltage rises above 6.2V or so. Its only purpose is to create a magnetic field to pull on the armature until the contact points close. By itself the magnetic field created by the inner coil is not strong enough to keep the points closed when subject to vibrating. Once the points close, the heavy-wire (**Outer Coil**) begins to conduct, creating a strong magnetic field that aids the inner coil in keeping the contacts firmly closed.

**Outer Coil**-The outer coil is made with a heavy wire and few windings. With the points closed current from the generator travels thru the outer coil charging the battery and strengthening the magnetic field around the iron core which prevents the points from vibrating open.

**Contact Points**-The contact points of the cutout act as a switch and are held "Normally Open" by the armature spring. When the speed of the generator increases a magnetic field is created closing the points, thus, allowing current from the generator to flow and charge the battery.

The point of "cut-in" (closure of points) is determined by the tension of the armature spring and the air gap between the iron core and contact arm. The contact points should close when the voltage of the generator has reached 6.1 to 6.3 volts. It is possible to change the "cut-in" by adjusting the air gap and/or bending the Armature Spring. (The "cut-in" charges the battery)

The point of "cut-out" (opening of points) is determined by the tension of the Armature Spring. The air gap between the contact arm and the iron core has little or no effect on the "cut-out". The cutout should occur when the ammeter reads between 0 and 2 amps. It is

possible to change the "cut-out" by bending the Armature Spring, set the "cut-out" as close to 0 as possible to prevent points from arcing and burning out. (The "cut-out" stops the charging of the battery and prevents the battery from draining)